

TELL EL-RETABA 2017. POTTERY IN CONTEXT¹

Anna Wodzińska²

Abstract: *The pottery from the 2017 excavation season at Tell el-Retaba was analyzed in its specific context of finding. Three periods have been selected for analyses: The Second Intermediate Period, the early 18th Dynasty and the Third Intermediate Period. The ceramic material selected for study was particularly associated with units located within well-defined layers – tombs and domestic structures. Although the majority of the vessels are well known at Tell el-Retaba, new forms also appeared, for instance, a fish vase. It seems that the early New Kingdom settlement was mostly provisioned. Material from the Third Intermediate Period testifies to all stages of food preparation. Some of the pots may reflect ritual usage of houses during the Third Intermediate Period.*

Keywords: *pottery, fish vessel, Tell el-Retaba, Second Intermediate Period, New Kingdom, Third Intermediate Period, cemetery, settlement*

The pottery from Tell el-Retaba found during the 2017 season included 3,673 diagnostic fragments. They can be dated to the Second Intermediate Period (3.4 % of all ceramic diagnostic fragments from the season), early 18th Dynasty (14.9 %), 19th–early 20th Dynasties (2.6 %), Third Intermediate Period (76.4 %), Late Period (2.2 %) and Ottoman period (0.5 %). The present paper includes selected material associated with units within well-defined structures from the Second Intermediate Period, the early 18th Dynasty and the Third Intermediate Period (Fig. 1).

Phase	Sub-phase	Dating	Main features
G	G3	Second Intermediate Period	Early open settlement and cemetery
	G2	Second Intermediate Period	Open settlement and cemetery
	G1	Second Intermediate Period	Open settlement and cemetery
F	F5 F4b F4a	Early 18th Dynasty	Cemetery – changes of burial practices The cemetery is overbuilt by a settlement Settlement of the so-called Green houses
	F3b F3a	Early 18th Dynasty	Settlements of the Green and Black houses Settlement of the so-called Black houses
	F2	Early 18 th Dynasty	Scattered settlement remains
	F1	late 18 th Dynasty	No archaeological record yet
	E		19 th Dynasty
D		20 th Dynasty	Fortress of the 20 th Dynasty
C	C4	Third Intermediate Period	Settlement
	C3b C3a	Third Intermediate Period	Settlement
	C2b C2a	Third Intermediate Period	Settlement
	C1	Third Intermediate Period	Settlement
B		Late Period	Settlement with tower houses
A		Modern	Ottoman ovens and pipes, among others

Fig. 1 Table showing the Tell el-Retaba phasing with highlighted sub-phases mentioned in the present paper.³

¹ Research financed by the Polish National Science Centre, grant 2015/17/B/HS3/00597.

² Institute of Archaeology, University of Warsaw.

³ Based on RZEPKA at al. 2017, 19–20; HUDEC et al. 2019.

Second Intermediate Period – cemetery⁴

Two of the tombs dated to the Second Intermediate Period – {2061} and {2500} from phase G2 – contained pottery. Ceramic finds indicate that the tombs can be dated to the second half of the 15th Dynasty, which relates well to strata D/3 and D/2 in Tell el-Dab^a.

Tomb {2061}

The tomb {2061} contained only one pot. It is a tall cup (Fig. 2) with a round, slightly flaring top of

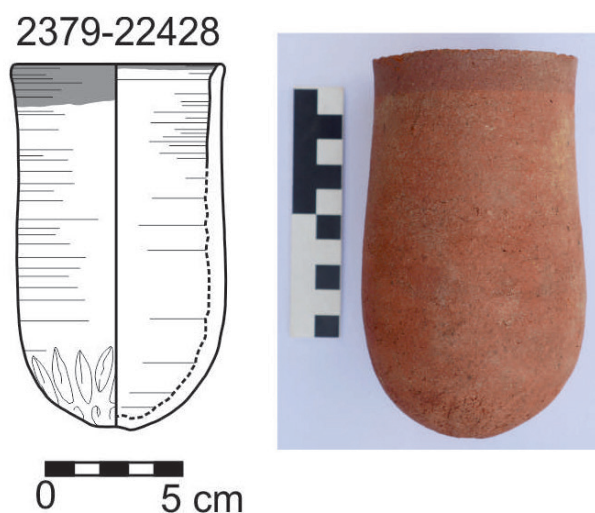

Fig. 2 Vessel from tomb {2061} (drawing K. Danys and A. Wodzińska, photo A. Wodzińska).

the rim, cylindrical body and round base with a slightly concave tip. It was wheel-made of Nile B2 fabric. Its surface is well smoothed, with a trimmed lower part of the body and base. Its rim, 7.6 cm in diameter, is painted red. It is very well preserved and was never used before placement in the tomb. The type is attested in Tell el-Dab^a in strata E/1,⁵ D/3⁶ and D/2⁷ (middle and second half of the 15th Dynasty), although the Tell el-Retaba example is more cylindrical in shape.

Tomb {2500}

The tomb {2500} contained two ceramic juglets. The first juglet (Fig. 3.1) has a funnel neck, round incurved rim with a flat spout, ovoid body, pointed base, and one handle with a round section. It is wheel-made of fine quality Nile B1. Its surface is red slipped and well burnished/polished. Its rim is 4.2 cm in width at the narrowest point. It is very well preserved, without any traces of use. This kind of pot is associated with many layers at Tell el-Dab^a,⁸ but the very slender variant can be attributed to strata E/1⁹ and D/3¹⁰, corresponding to the middle and second half of the 15th Dynasty.

The second pot is a small juglet (Fig. 3.2) with a narrow cylindrical neck, biconical body (6 cm in the max. diameter), knob base, and a loop handle with a flat, rectangular section. Its rim is missing. The fabric is uncertain but seems to be marl A4. Its external surface is burnished and the interior is



Fig. 3 Vessels from tomb {2500} (drawings K. Danys, K. Szymańska, and A. Wodzińska, photos A. Wodzińska).

⁴ For a description of the Second Intermediate Period and early 18th Dynasty structures, see HUDEC et al. 2019.

⁵ BIETAK 1991, 196, Fig. 150.4.

⁶ BIETAK 1991, 250, Fig. 217.10.

⁷ FORSTNER-MÜLLER 2008, 326, Fig. 245b.36 (no. 8804A).

⁸ E.g. FORSTNER-MÜLLER 2008, 195, Fig. 114.4 (nos. 1657 and 1663), stratum E/3, see also 255, Fig. 189c.49 (no. 1397), stratum E/1.

⁹ ASTON 2004, 370, Fig. 94. v, group 285.

¹⁰ BIETAK 1991, 275, Fig. 248.1.

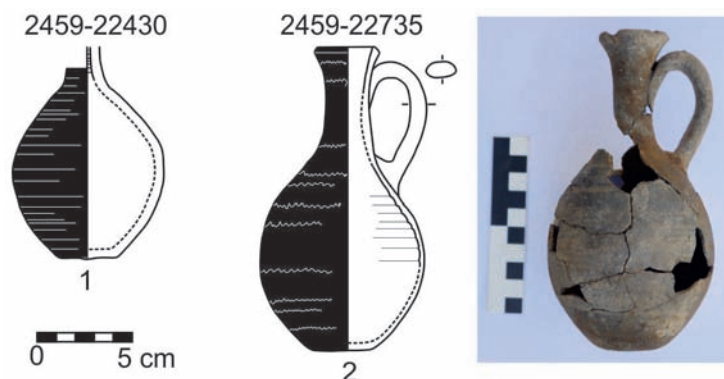

Fig. 4 Black burnished juglets from tomb {2458} (drawings K. Danys, B. Jakubowska, K. Szymańska, and A. Wodzińska, photo A. Wodzińska).

smoothed. It is decorated with red painted straight and wavy horizontal lines on the external surface and on the handle. The pot was found covered with some sort of white patina. It is probably a painted Tell el-Yahudiya ware juglet. Its shape does not exactly fit the range, but the identification seems correct nonetheless.¹¹ It is most probably an Egyptian rather than a Palestinian product.¹² Some parallels to the vessels can be found in Tell el-Dab^ca in strata E/2 and D/2.¹³

Early 18th Dynasty

Material from the early 18th Dynasty was found in two general contexts: Funerary and domestic, the latter associated with the so-called Green and Black Houses.

Early 18th Dynasty tombs

Two tombs, {2458} and {2513}, contained pottery, which, according to the site stratigraphy, can be placed in phase F5 corresponding to the earliest occupation of the early 18th Dynasty at Tell el-Retaba.

Tomb {2458}

Of four vessels found in the tomb {2458}, two are wheel-made juglets (Fig. 4). One of them is missing a rim (Fig. 4.1) but seems to belong to the

same type as the second one (Fig. 4.2). The better-preserved juglet has a globular body and flat base (3 cm in diameter), flaring rim (3.5 cm in diameter), narrow neck, and a single vertical handle. Both vessels are made of the same material – Nile B2. Their external surface is covered with black slip and burnished. They are most probably imitations of Cypriot Black Lustrous Wheel-made ware, vessels known from many sites in Egypt and Nubia.¹⁴ The closest parallels found in funerary contexts come from early 18th Dynasty tombs in the vicinity of the Teti pyramid at Saqqara.¹⁵ Such juglets were also found in several early New Kingdom tombs at Gurob.¹⁶

Tomb {2458} also contained one small jar made of Nile B2 clay (Fig. 5.1). It is a small vessel with an ovoid body, pointed base and flaring rim, measuring 8.6 cm in diameter. Its external surface is covered with red slip and smoothed. Small jars like this can be found in early 18th Dynasty tombs, for example, in Gurob.¹⁷

The fourth vessel found in the tomb is a large Nile B2 jar with an ovoid body, narrow flat base and flaring rim, 11.5 cm in diameter (Fig. 5.2). Its external surface is covered with red slip and smoothed. It has a black painted spiral band on the external surface and a black painted rim. It was wheel-made, with a trimmed tip of the base. A very similar jar was found in one of the tombs discovered in Tell el-Koa¹⁸ located very close to Tell el-Retaba. Exact parallels were found in Gurob, in

¹¹ For the general idea, see BAGH 2013, 208–209, Fig. 28; pots coming from Tell el-Dab^ca are generally associated with the stratum E/1.

¹² David A. Aston, personal communication.

¹³ FORSTNER-MÜLLER 2008, 229, Fig. 154.1 (no. 4031), stratum E/2, and 381, Fig. 307.2 (no. 8706), stratum D/2.

¹⁴ For a general overview, see HÖRBURGER 2007.

¹⁵ FIRTH and GUNN 1926, 66, Fig. 74, nos 4–5, Pl. 48D, nos 1–2.

¹⁶ BRUNTON and ENGELBACH 1927, Pl. XXI, from tomb 293 (dated in the publication to the period between Ahmose and Amenhotep I), Pl. XXII, from tomb 27 (dated to the reign of Amenhotep I), see also Pl. XXXIX, nos. 91M, 91N and 91Q.

¹⁷ BRUNTON and ENGELBACH 1927, Pls. XXI (tomb 76) and XXXIV, no. 25a.

¹⁸ EL-HANGOURY 2003.

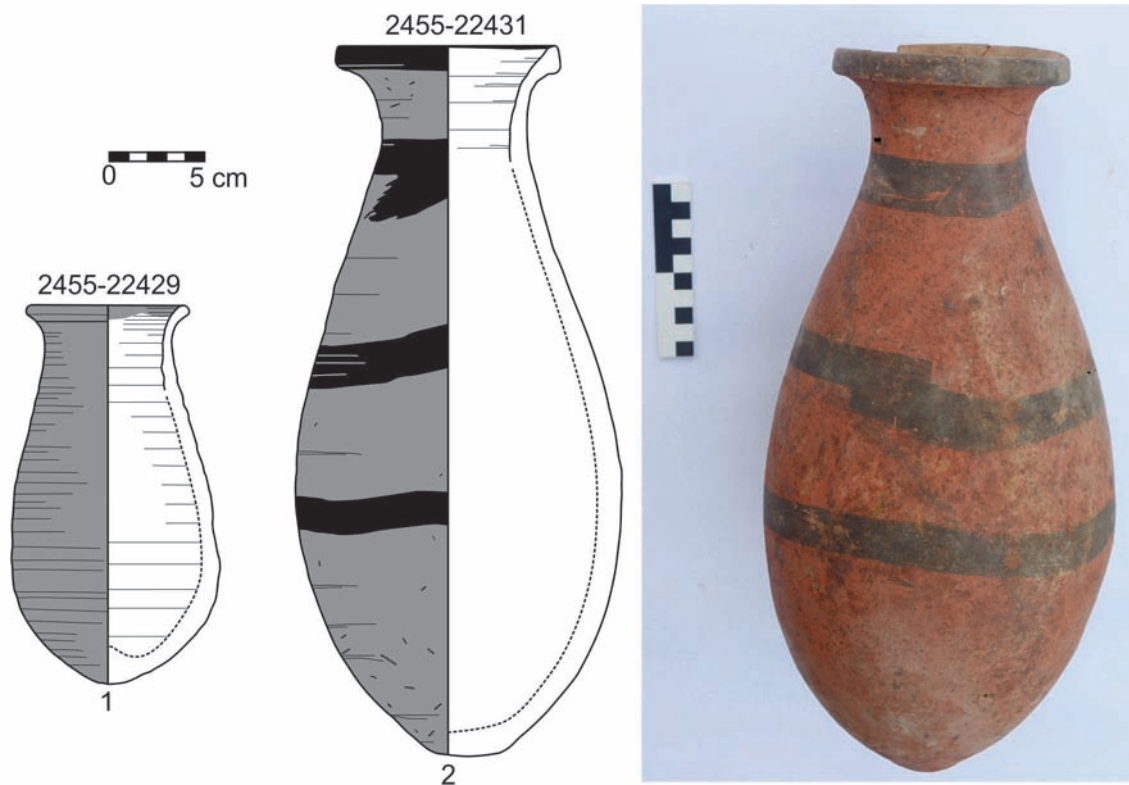

Fig. 5 Two red slipped jars from tomb {2458} (drawing K. Danys and A. Wodzińska, photo A. Wodzińska).

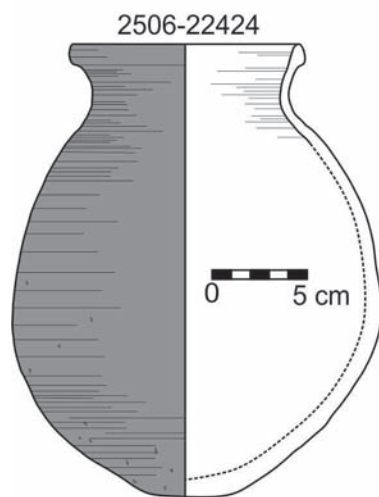

Fig. 6 Jar from tomb {2513} (drawing K. Danys and A. Wodzińska, photo A. Wodzińska).



early New Kingdom tombs.¹⁹ It is interesting to note that those black burnished juglets were found in the same tombs as the large jars with black painted decoration,²⁰ as was the case in Tell el-Retaba.

Tomb {2513}

One jar (Fig. 6) with a globular body, round, slightly flattened base, short cylindrical neck and flaring triangular rim (12 cm in diameter) was

¹⁹ BRUNTON and ENGELBACH 1927, Pl. XXXIV, nos. 24D (tomb 26), 24H (tomb 27), and 24H (tomb 288).

²⁰ BRUNTON and ENGELBACH 1927, Pl. XXII, tomb 27, and Pl. XXIII, tomb 26.

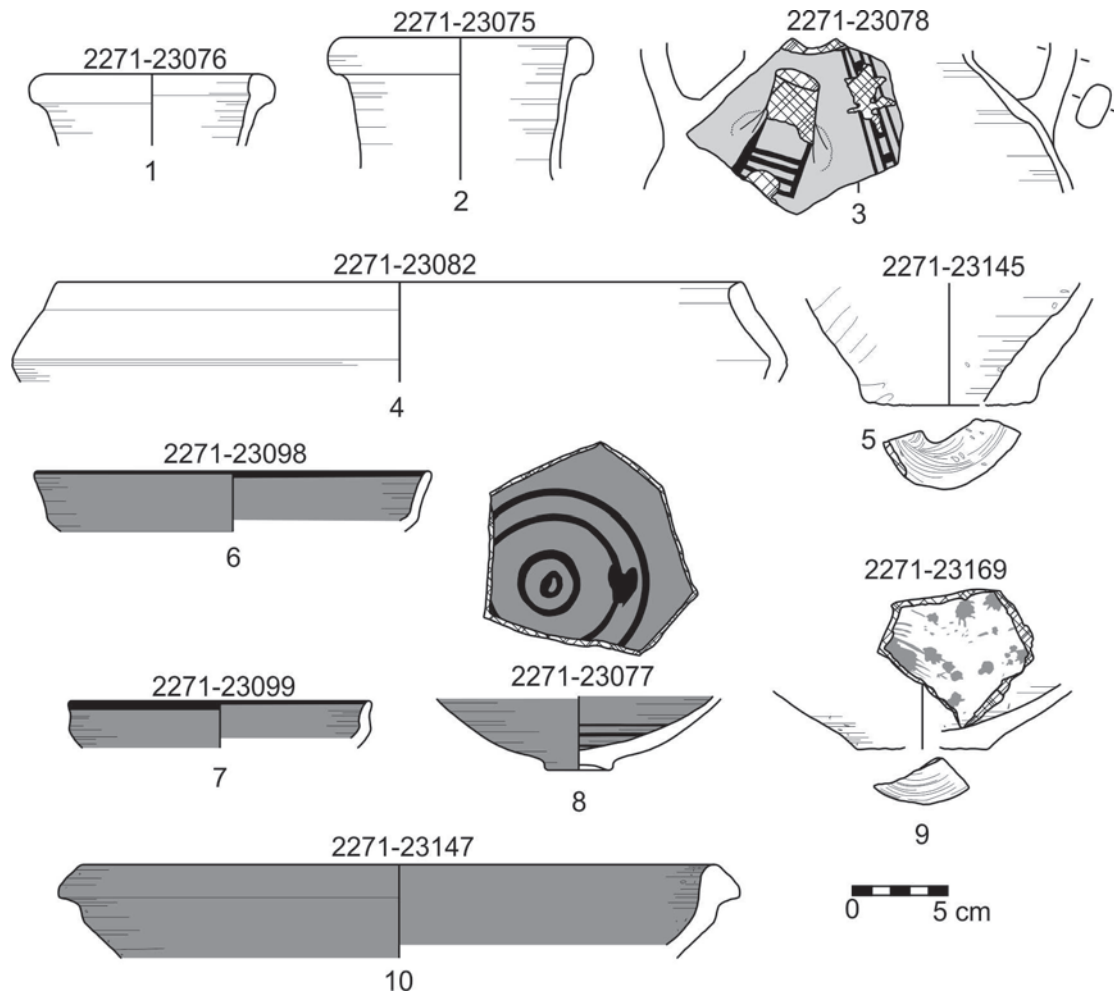

Fig. 7 Selected ceramic vessels from unit (2271), Black house {1}
(drawing K. Danys, B. Jakubowska, K. Szymańska and A. Wodzińska).

found in tomb {2513}. It is made of Nile B2 fabric, covered with red slip and burnished. Such jars are well attested in Wadi Tumilat.²¹ They were also placed in tombs of the early New Kingdom in Gurob.²²

The tombs discovered during the 2017 season seem to represent the earliest occupation of the site during the early 18th Dynasty. The pottery is clearly of Egyptian production. It is very difficult to say with whose reign the material can be connected, but the tomb structures²³ and the pottery placed within point to Thutmosis III.

Early 18th Dynasty – settlement area

Material from the early 18th Dynasty was mainly associated with the so-called Black Houses. Pottery (Fig. 7) from one of the units, (2271) of phase F3a, well represented material from Black house 1. The unit is a large deposit, probably a rubbish heap, containing ashes and charcoal with large quantities of pottery, animal bones and flints. It contained amphorae of Egyptian production, made of marl D2 with smoothed surface (Fig. 7.1–2), 13 and 14 cm in diameter, respectively.²⁴ The deposit

²¹ For instance, in Tell el-Koa, EL-HANGOURY 2003.

²² BRUNTON and ENGELBACH 1927, Pl. XXIII, no. 42, tomb 26 (dated to the period between Amenhotep I and Thutmosis III), see also Pl. XXXV, nos. 31N, 31O.

²³ HUDEC et al. 2019.

²⁴ For comparison, see BOURRIAU 2010, Fig. 32, number 10.14.3.

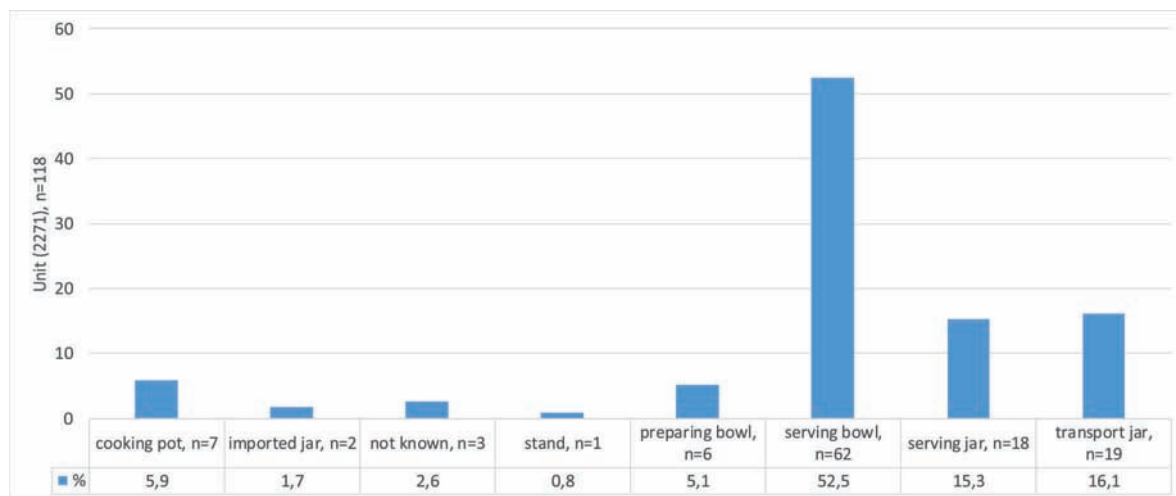

Fig. 8 Pots in unit (2271) grouped according to their general function.

also featured a number of imitations of so-called bichrome ware made of marl A4, with black painted decoration (e.g. Fig. 6.3). Closed forms were represented by cooking pots made of Nile B2 with blackened external surfaces (Fig. 7.4), 27 cm in diameter. The best parallels to these vessels can be found in Memphis in level IV, dated to the early to mid-18th Dynasty.²⁵ The assemblage recovered from the unit also included a so-called flowerpot with a hole in the base made before firing, manufactured of Nile E fabric. Its base, 9 cm in diameter, was cut from the potter's wheel with a string (Fig. 7.5). Open form vessels were represented mainly by carinated²⁶ and hemispherical bowls made of Nile B2 fabric with a red slipped, smoothed surface and black painted rims (Fig. 7.6–7), 16 and 21 cm in diameter, respectively. One of the bowls was decorated with black circles painted on its internal surface (Fig. 7.8), base 3.5 cm in diameter. It is noteworthy that hemispherical bowls made of Nile B2 with so-called red splashed decoration appeared for the first time in Tell el-Retaba (Fig. 7.9), base 7 cm in diameter, during the second phase of the early 18th Dynasty. According to Aston,²⁷ such material can be dated to the period between Thutmose III and Amenhotep II.²⁸ The pottery in unit (2271) also includes large basins, each with a triangular recurved rim, 36 cm in diameter, made of Nile B2 and red slipped and smoothed internal and external surfaces (Fig. 7.10).

The unit (2271) contained 118 diagnostic fragments. When all the pots are grouped according to their functions (cooking pots, stands, preparing, serving bowls and jars, transport jars – Fig. 8), it becomes clear that the assemblage consists mostly of serving bowls (52.5 %). There are also small serving jars (15.3 %) and transport amphorae (16.1 %). Importantly, the material does not contain any storage jars. Overall, it seems that the unit contained mostly tableware – vessels used mostly during the serving/consumption of food. There is some cooking activity noted but on a very small scale.

Third Intermediate Period settlement

Several buildings dated to the Third Intermediate Period were excavated during the 2017 season.²⁹ The structures contained numerous ceramic fragments but only some of them can be associated with direct use. Pottery from the following buildings is described below: {991}, {2147}, {2196}, {2640}, {2644}, and {2715}.

Building {991}³⁰

Four conical cups (Fig. 9), rims 10.3, 12.5, 13 and 13 cm in diameter, respectively (of the same type as in Figs. 14.2 and 21), were found in unit (2623) of building {991} (phase C3b). They were located in a round cut in an open space. They may have

²⁵ BOURRIAU 2010, Fig. 26, number 7.6.4.

²⁶ See BOURRIAU 2010, Fig. 23, numbers 4.5.2, 4.5.5.

²⁷ ASTON 2006.

²⁸ See also BOURRIAU 2010, Fig. 21, number 3.2.3, for early to mid-18th Dynasty.

²⁹ For a detailed description of the structures, see JARMUZEK et al. 2019.

³⁰ JARMUZEK et al. 2019, Fig. 2.

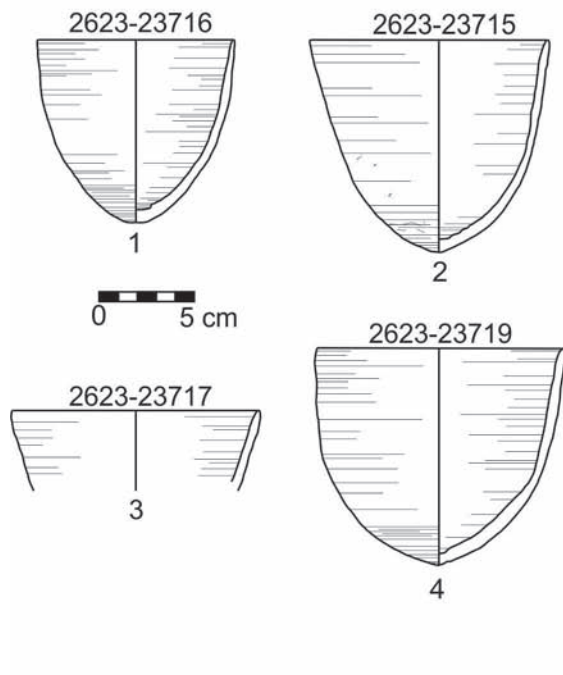

Fig. 9 Cups from unit (2623), building {991} (drawing K. Danys and A. Wodzińska, photo S. Rzepka).

been left there after use or simply stored for further use. The conical cup is one of the most characteristic pots from the Third Intermediate Period. It is made of sandy Nile B2 fabric, with smoothed surface and trimmed base. As in the case of similarly shaped cups of the Middle Kingdom,³¹ they were probably used for drinking or simply for picking up water.

Building {2147}

*Phase C3b*³²

Building {2147} in phase C3b contained several vessels found in situ.

Two storage jars in units (2240) and (2213) were located in Room 1. The first one was preserved only fragmentarily. The second, a large jar with two handles, was located in a corner and was probably used to store water.³³

The almost complete vessel 2610-24179 was found in the floor (2612) in Room 4. It is a jar with

a cylindrical neck, straight round rim (9 cm in diameter), biconical body, and pointed base (Fig. 10.1). It is made of Nile B2 fabric. Its surface is smoothed. It is not clear how the pot was used in this context. Jars of similar shape were often used as cooking pots, but the pot in question was not covered with soot, neither does it bear any traces of burning. It may have served as a storage vessel, but it is impossible to determine the type of commodities kept within.

A large fragment of a vessel was found more or less in the middle of Room 3 (Fig. 10.2). It seems originally to have been a jar of a similar type to the one shown in Fig. 10.1. It is made of Nile B2 clay and its surface is smoothed. Its rim and neck had already been broken off around the time of its production. The edges of the preserved base were smoothed, and the jar became a basin. Therefore, the function of the pot was changed from storage to probably preparation of food (mixing of ingredients).

³¹ E.g. SCHIESTL AND SEILER 2012, 84–87.

³² JARMUZEK et al. 2019, Figs. 2–3.

³³ Already published in RZEPKA et al. 2017, 61, Fig. 72.

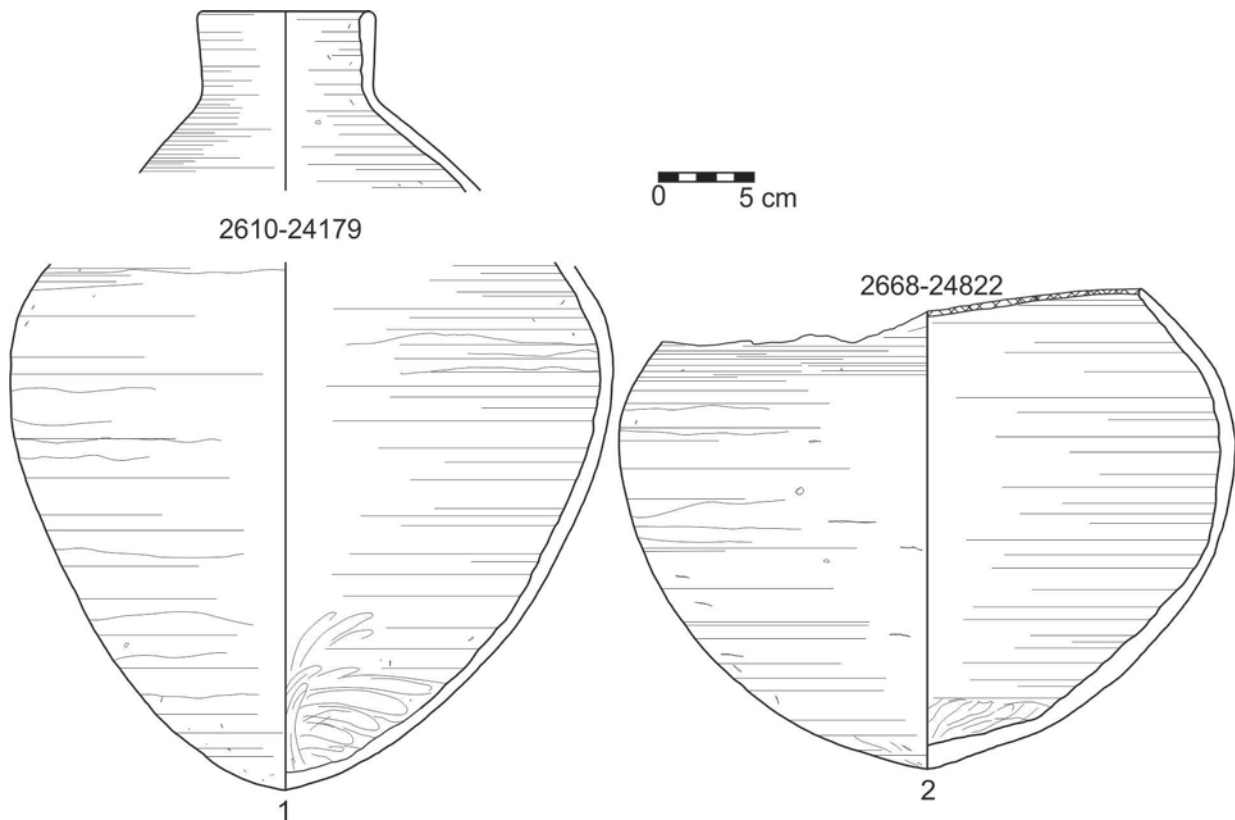

Fig. 10 Jars from units (2610) and (2668), building {2147}; (drawing K. Danys and A. Wodzińska).

Phase C3a³⁴

A large lower part of a jar with a narrow flat base, 3.5 cm in diameter (Fig. 11a), was found standing in a cut <2650> in the western part of the courtyard of building {2147}, in front of room 3, in phase C3a. It was placed in the large cut with a much greater diameter than the pot itself (Fig. 11b). It is made of Nile B2 fabric and has a smoothed surface. The upper part of its body was protected with a string during the process of manufacture. It was used most probably as a storage vessel.

Another pot (Fig. 12) was also found in the courtyard, in unit (2751), in front of the entrance to Room 4. Only the pointed base of the jar is preserved. It is made of Nile B2 clay. Its external surface is well smoothed and the interior was smoothed by hand, as indicated by clear finger impressions. The upper part of the vessel is not preserved, but it seems to have been of the same type as the jars in Fig. 10.

³⁴ JARMUZEK et al. 2019, Fig. 13.

³⁵ JARMUZEK et al. 2019, Fig. 14.

³⁶ For identification, see BREWER and FRIEDMAN 1989, 76–79.

³⁷ CROWFOOT PAYNE 1993, Fig. 23, no. 108.

Phase 2Cb2³⁵

A unique vessel was found in the fill (2691) of the oven {2677}, in the space between building {2147} and building {1095}. It is a handmade, probably mold-formed, fish-shaped jar made of Nile B1 clay, covered with thick red slip and burnished (Fig. 13). Only a fragment of the pot is preserved – the backside – but characteristic features of a fish are visible: The dorsal, anal and caudal fins. There is also a sort of pipe added behind the dorsal fin, forming the vessel's neck and rim. The fish's mouth is missing, so, it is not clear if the pot had one rim or perhaps two. The vessel most probably represents a tilapia,³⁶ which was often depicted during the New Kingdom. There is no direct parallel to the vessel.

The following variants of fish-shaped pots known from Egypt can be distinguished:

- Vessel with a rim at the fish's mouth, made of clay – Naqada I,³⁷ Second Intermediate Period,³⁸ early 18th Dynasty³⁹

³⁸ FORSTNER-MÜLLER 2008, 348, Fig. 273.4; see also ASTON and BIETAK 2011, 524–526, Pls. 113–114.

³⁹ Reign of Thutmose III; see GEUS 2004, 120, Fig. 95; DREYFUS 2005, 242, Fig. 171.



Fig. 11a Jar from unit (2649), building {2147} (drawing K. Danys and A. Wodzińska, photo A. Wodzińska).

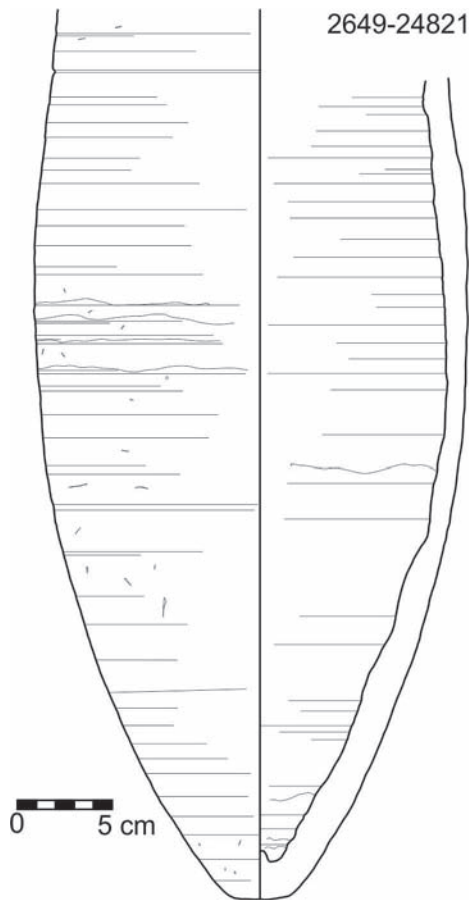

Fig. 11b Jar from unit (2649), building {2147} (photo S. Rzepka).



Fig. 12 Jar from unit (2751), building {2147} (drawing K. Danys and A. Wodzińska, photo S. Rzepka).

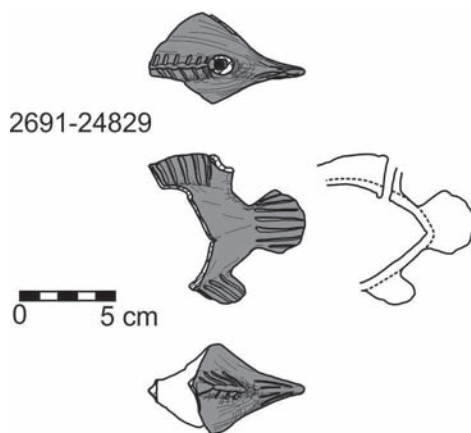

Fig. 13 Fish-shaped vessel from unit (2691), oven {2677} located between buildings {2147} and {1095} (drawing K. Danys and A. Wodzińska, photo A. Wodzińska).



- Vessel with rim at the fish’s mouth, made of stone – Second Intermediate Period,⁴⁰ New Kingdom⁴¹
- Vessel with rim at the fish’s mouth, made of faience – New Kingdom⁴²
- Vessel with rim at the fish’s mouth, made of glass – New Kingdom⁴³

- Vessel with wide rim at the fish’s nape, made of clay – Naqada II,⁴⁴ Middle Kingdom/New Kingdom⁴⁵
- Vessel with narrow neck and rim at the nape, added to in front of the dorsal fin, made of faience – Late Period.⁴⁶

No tilapia-shaped vessels are known from the Third Intermediate Period. Based on the manufac-

⁴⁰ FAY 1998, 26, Fig. 14.

⁴¹ 18th Dynasty, Brooklyn Museum, inv. no. 11.668 <https://www.brooklynmuseum.org/opencollection/objects/3065> (accessed May 12, 2019).

⁴² 18th Dynasty, The Los Angeles County Museum of Art, inv. no. AC1999.57.1 <https://collections.lacma.org/node/189331> (accessed May 12, 2019).

⁴³ 18th Dynasty – British Museum, inv. no. EA55193, RUSSMAN 2001, 164, Fig. 76; see also Brooklyn Museum, inv. no. 37.316E <https://www.brooklynmuseum.org/opencollection/objects/4014> (accessed May 12, 2019).

⁴⁴ CROWFOOT PAYNE 1993, Fig. 50, no. 929.

⁴⁵ Private collection <http://www.antiques.com/classified/1094495/Antique-Middle-New-Kingdom-Terracotta-Vessel-in-the-Form-of-a-Fish---LO-1311> (accessed May 12, 2019).

⁴⁶ Private collection <https://phoenixancientart.com/work-of-art/egyptian-faience-aryballos-in-the-shape-of-a-fish-tilapia-nilotica/> (accessed May 12, 2019); see also VANDIER D’ABBADIE 1972, 96–97, no. 377.

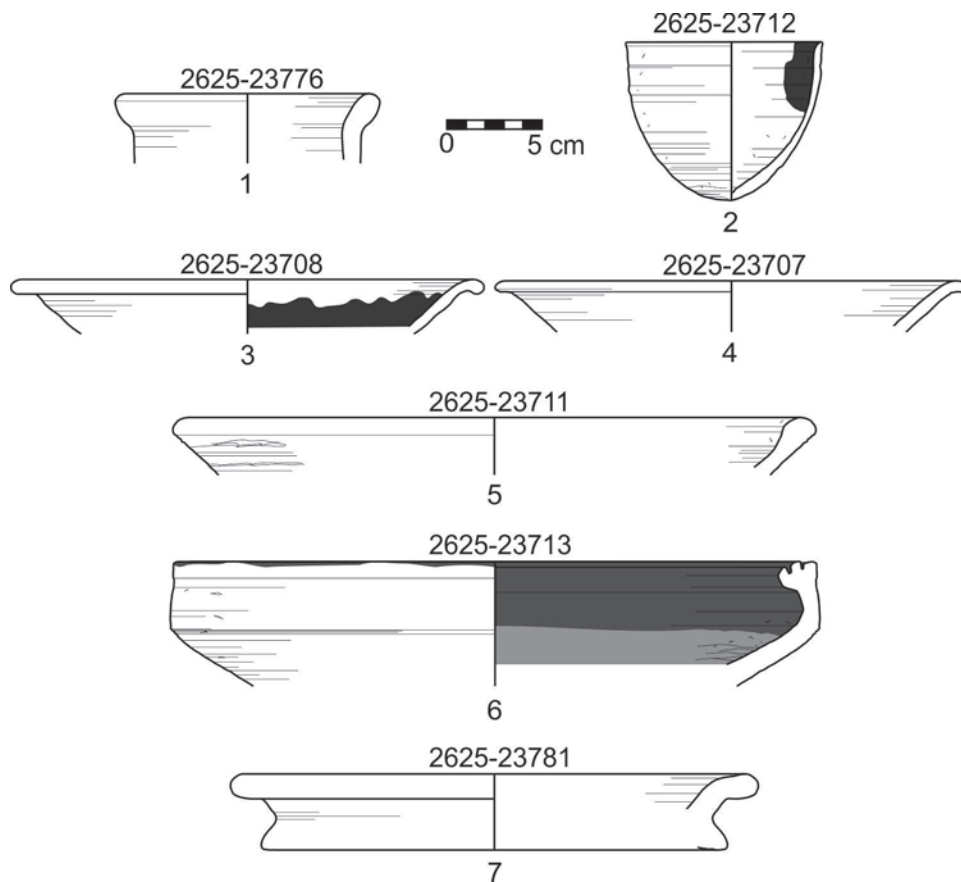

Fig. 14 Selected pots from unit (2625), space between buildings {2147} and {1095} (drawing K. Danys, B. Jakubowska, and A. Wodzińska).

ture and surface treatment, the fish-vessel from Tell el-Retaba fits the New Kingdom production of figure vases better.⁴⁷ Perhaps the vessel fragment was made during the New Kingdom, possibly in the late 20th Dynasty, and was used throughout the early Third Intermediate Period. It is clearly an object of good quality, valuable not only for its contents (ointments?) but also for its general appearance.

An oval cut <2626> was found to the south of oven {2677}, filled with ashy deposit (2625), which contained an assemblage of pottery shown in Fig. 14. It included a storage jar with a round flaring rim (14 cm in diameter) and cylindrical neck, made of Nile E (Fig. 14.1). Present among the group of open forms were conical cups made of Nile B2 sandy fabric. One of the cups was almost complete (Fig. 14.2), 10.4 cm in diameter. Its internal body was partly burned, probably due to secondary usage as a lamp. There were also several bowls with round flaring and recurved rims, 25 cm in diameter, made of Nile B2 fabric with a smoothed surface (Fig. 14.3–4). Some of them are burned inside (Fig. 14.3), possibly due to their use

for heating food and perhaps also for keeping burned charcoal. Other characteristic bowls of the Third Intermediate Period are forms with thickened flaring rims, 34 cm in diameter, made of Nile B2 fabric (Fig. 14.5). Their walls were protected with string during the process of production. Bread molds made of Nile C fabric, each with a round, flaring rim, 27 cm in diameter, and a flat base were also found in the unit (Fig. 14.7). One of the bowls is very distinctive (Fig. 14.6). It is a large basin made of Nile B2, with bent walls and a triangular rim (34 cm in diameter) with three deep grooves. Its internal surface, covered with red slip and smoothed, was burned during usage. It perhaps served as a lid for a cooking pot. The assemblage also consisted of jars with cylindrical necks and round straight rims used for cooking (see also jars in Fig. 19), and fragments of hole-mouthed storage jars.⁴⁸ The unit (2625) can generally be associated with storage, preparation (including the baking of bread) and serving of food. It seems to have been suited for typical domestic activity without any special functions.

⁴⁷ E.g. BOURRIAU 1987.

⁴⁸ E.g. WODZIŃSKA 2011, 1034, Fig. 10.4; 2015, 530, Fig. 4.

Building {2196}⁴⁹

Two complete plates (11.5 and 12.2 cm in diameter) with conical bodies and flat bases (Fig. 15a) were found in an ashy unit (2703), a fill of a round cut <2704>, made in floor (2549) (Fig. 15b) in building {2196}. The plates had smoothed surfaces and were made of sandy Nile B2 fabric. They were clearly made on a fast wheel and their bases were cut from the wheel with a string. Overall, it seems that the plates were made by the same potter. Their fabric is very similar to the material used in the production of conical cups. However, the types are unique, unattested so far at the site. Their general appearance may point to ritual use, as in the case of miniature plates of the Old Kingdom,⁵⁰ bowls with flat bases, and miniatures of the Middle Kingdom⁵¹ and the Late Period⁵² used in funerary contexts. The manner of their deposition (Fig. 15b) may indicate they were intentionally/ritually broken, but this is very hard to prove.

Building {2640}⁵³

Several floors were distinguished in building {2640}: Units (2718), (2710), (2692), (2687),

(2686), (2679), (2673), (2663), (2653) (phases C2–C1). All of them contained pottery, but the material was very fragmentarily preserved; it is not clear if it reflects the use of space in a direct fashion. Two units, (2663) and (2710), may have contained material that is more representative of the area, although generally, neither of the assemblages can be associated with any particular function.

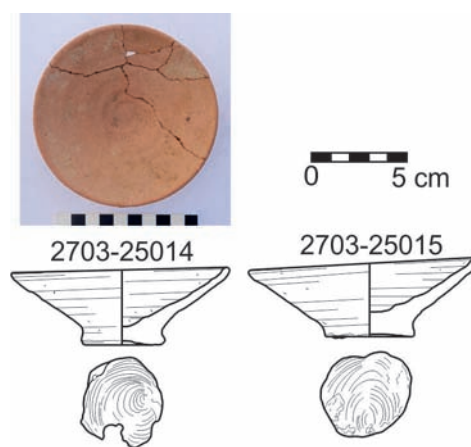

Fig. 15a Two plates from unit (2703), building {2196} (drawing K. Danys and A. Wodzińska).

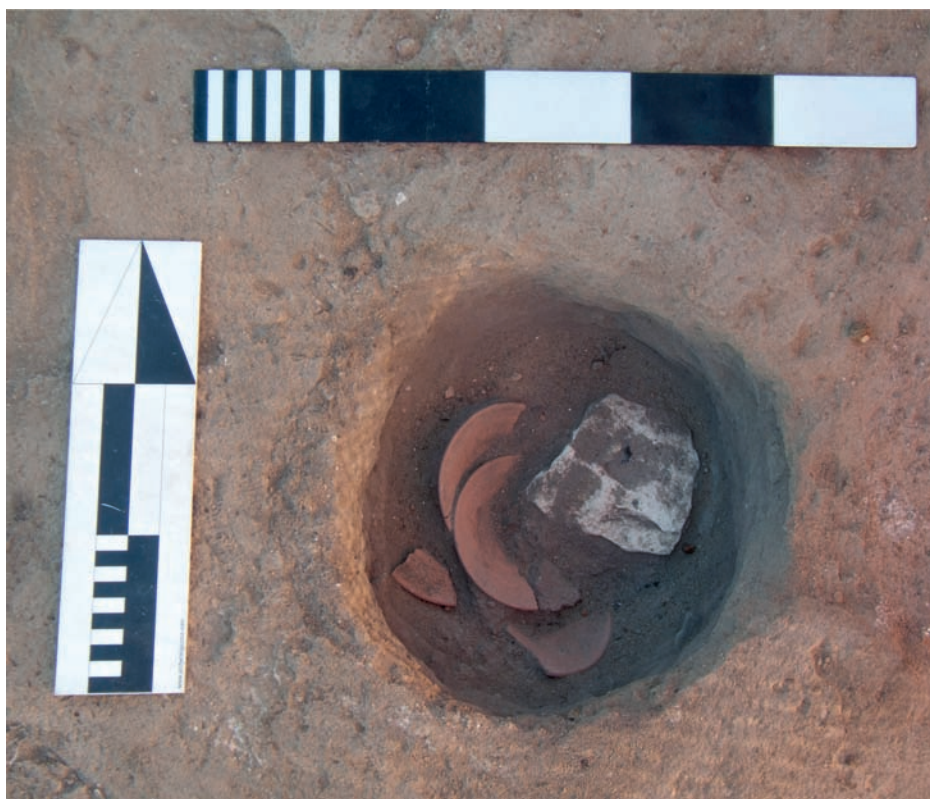

Fig. 15b Plates from unit (2703), building {2196} (photo S. Rzepka).

⁴⁹ JARMUZEK et al. 2019, Fig. 30.

⁵⁰ E.g. RZEUSKA 2006, 424–425.

⁵¹ E.g. BABA and YOSHIMURA 2011, 165–166, Fig. 5.

⁵² RZEUSKA 2001, 321–323, nos. 31–32.

⁵³ JARMUZEK et al. 2019, Fig. 32.

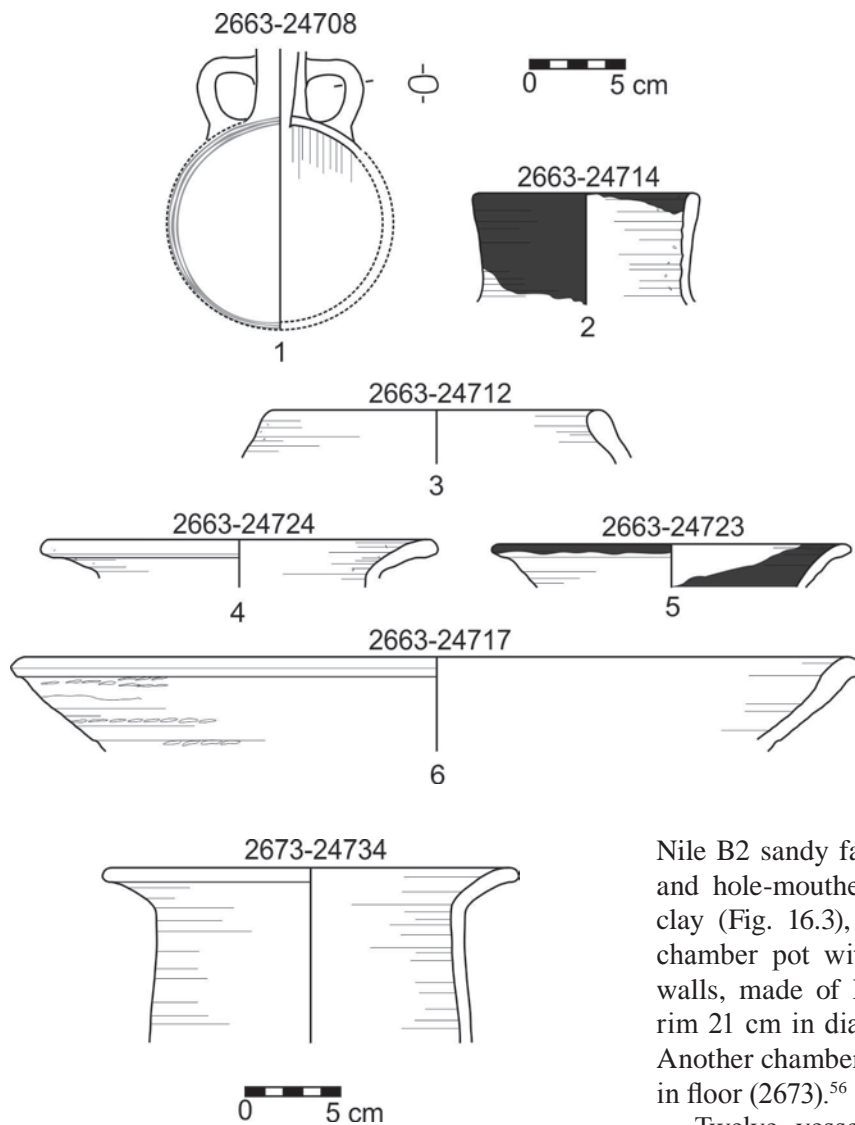

Fig. 17 “Chamber pot” from floor (2673), building {2640}
(drawing B. Jakubowska and A. Wodzińska).

Floor (2663) yielded 33 ceramic vessels (Fig. 16), mostly for serving and food preparation. A fragment of a pilgrim flask (Fig. 16.1), made of Nile B1 fabric with red painted circles, finds a good parallel in Qantir in a layer dated to the early Third Intermediate Period.⁵⁴ There are also Nile B2 bowls with a round, flaring rim, 19 cm in diameter, often burned (Fig. 16.5), and large platters, rims 47 cm in diameter, made of sandy Nile B2 fabric, with string impressions on the external surface (Fig. 16.6).⁵⁵ The collection includes cooking jars (Fig. 16.2), 12 cm in diameter, made of

⁵⁴ ASTON 1998, 548–549, nos. 2235–2238.

⁵⁵ For comparison, see ASTON 1998, 586, nos. 2418–2421.

⁵⁶ For identification, see ASTON 1998, 550, no. 2241.

Fig. 16 Selection of pottery from floor unit (2663) in building {2640}
(drawing K. Danys, B. Jakubowska, and A. Wodzińska).

Nile B2 sandy fabric, often with burned surfaces, and hole-mouthed storage jars made of Nile B2 clay (Fig. 16.3), 17 cm in diameter. A so-called chamber pot with a round flaring rim and bent walls, made of Nile B2 sandy fabric (Fig. 16.4), rim 21 cm in diameter, was also among the finds. Another chamber pot fragment (Fig. 17) was found in floor (2673).⁵⁶

Twelve vessels were found on floor (2710). Among the finds is a small pilgrim flask made of Nile B1 clay with a red slipped and smoothed external surface decorated with black painted circles and black strokes on the handle (Fig. 18.1).⁵⁷ The assemblage also included conical cups (Fig. 18.2), rims 12 cm in diameter, and bowls with flaring rims (Fig. 18.3), 30 cm in diameter. In addition, the material contained one bread mold (Fig. 18.4), rim 25 cm in diameter.

Bin [2685]⁵⁸ contained a storage jar, of which only the base was preserved. The jar was made of Nile B2 fabric, covered with red slip and smoothed. A similar jar was found in building {2149} excavated at Tell el-Retaba during the 2016 season.⁵⁹

⁵⁷ See ASTON 2007, 55, Fig. 51, nos. 589–590, pottery from 11th–10th century BC.

⁵⁸ See JARMUZEK et al. 2019, Fig. 34.

⁵⁹ RZEPKA et al. 2017, 72, Fig. 102.

There were several small cuts: <2655>, <2657>, <2659>, <2661> and <2671>, in floor (2663). Some of them were filled with small pieces of pottery; cut <2661> contained a very small rim fragment of a conical cup (similar to that in Figs. 19 and 21), and unit (2657) included a very small and eroded transport amphora rim. Two rims (both 11 cm in diameter) belonging to jars used as cooking vessels (Fig. 19) were in cut <2671>. One of them (Fig. 19.1) was made of dense Nile B2 and had a smoothed surface. It had been severely burned during usage. The rim comprised two glued sherds, one of which was found in cut <2657>. The second jar (Fig. 19.2) with a smoothed surface was made of sandy Nile B2.

Building {2644}⁶⁰

A room constituting a part of building {2644} was used as a rubbish dump during phase C3b. It was partly filled with ashes, including layer (2681). The pottery from the unit displays characteristic forms of the early Third Intermediate Period. Fig. 20 shows a selection of them. There is a pilgrim flask with two small handles and a simple flaring rim, 6 cm in diameter, made of Nile B2 fabric (Fig. 20.1). Large storage vessels are represented by a rim fragment of a jar (23 cm in diameter) with a thickened rim, made of dense NB2 fabric,

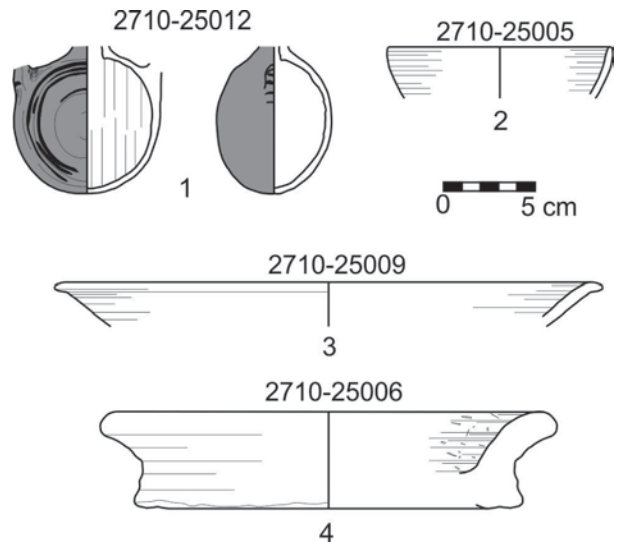

Fig. 18 Selection of ceramic vessels from floor (2710), building {2640} (drawing K. Danys, B. Jakubowska, and A. Wodzińska).

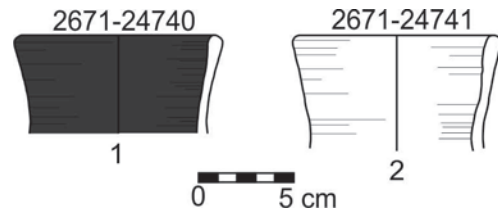

Fig. 19 Pots from cut <2671> in floor (2663), building {2640} (drawing B. Jakubowska and A. Wodzińska).

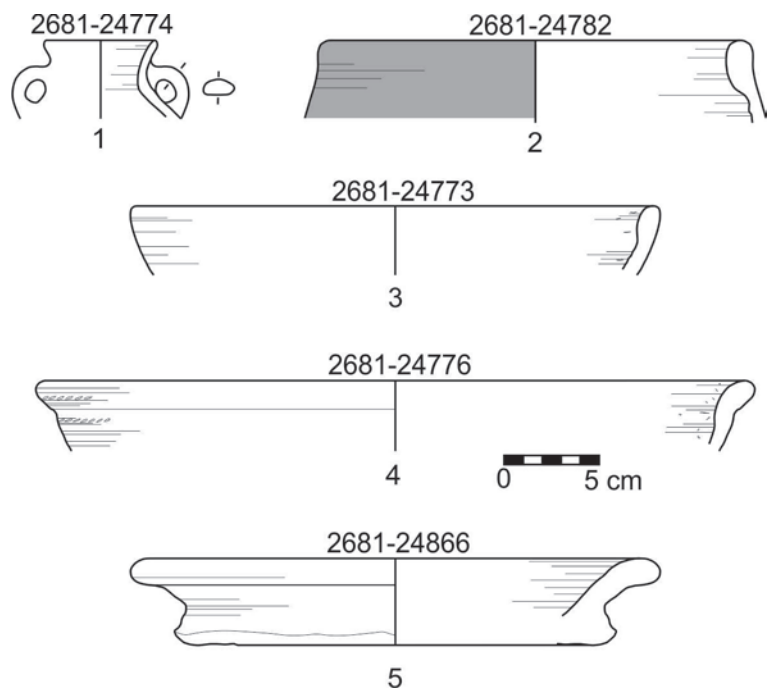

Fig. 20 Selected ceramic vessels from unit (2681), building {2644} (drawing B. Jakubowska and A. Wodzińska).

⁶⁰ JARMUZEK et al. 2019, Fig. 14.

covered with pinkish slip and smoothed (Fig. 20.2). Hemispherical bowls with slightly incurved round rims (28 cm in diameter) made of sandy Nile B2, with smoothed surfaces (Fig. 20.3), are also distinctive. The material includes a large basin, also made of sandy Nile B2 clay, with a flaring thickened rim, 38 cm in diameter. Its surface is smoothed, with visible impressions of string on the exterior (Fig. 20.4). Bread molds made of Nile C fabric were also present in the assemblage (Fig. 20.5), rims 28 cm in diameter.

Looking at the whole assemblage, it appears that all activities associated with the storage, preparation and serving of food, including the baking of bread, are represented. Therefore, we cannot distinguish any specific function of the pottery associated with unit (2618) or with the fragment of the building {2644} the material was found in.

Building {2715}⁶¹

A small conical cup, 15 cm in diameter (Fig. 21), was found in unit (2744) (Phase C3a). Interestingly, the pot was found inside a bin in a courtyard belonging to building {2715}. It may have been left there by someone performing activities in the courtyard, therefore, we cannot exclude the possibility that it served a different function, for instance, as a measuring cup, perhaps for grain.

Conclusions

New tombs of the Second Intermediate Period were excavated, showing more material from the middle and second half of the 15th Dynasty.

Bibliography

- ASTON, D.A.
 1998 *Die Keramik des Grabungsplatzes Q I*, Forschungen in der Ramses-Stadt. Grabungen des Pelizaeus-Museums Hildesheim in Qantir-Pi-Ramesse, 1, Mainz am Rhein.
 2004 *A Corpus of Late Middle Kingdom and Second Intermediate Period Pottery*. Tell el-Dab^a XII, Vienna.
 2006 Making a Splash: Ceramic Decoration on the Reigns of Thutmosis III and Amenophis II, 65–74, in: E. CZERNY, I. HEIN, H. HUNGER, D. MELMAN, S. SCHWAB (eds.), *Timelines, Studies in Honor of Manfred Bietak*, vol. 1, OLA 149, Leuven.
- 2007 Pottery of the Twelfth to Seventh Centuries BC, 17–59, in: D.G. JEFFREYS and D.A. ASTON (eds.), *The Survey of Memphis III: The Third Intermediate Period Levels*, London.
- ASTON, D.A. and BIETAK, M.
 2011 *The Classification and Chronology of Tell el-Yahudiya Ware*, Tell el-Dab^a VIII, Vienna.
- BABA, M. and YOSHIMURA, S.
 2011 Ritual Activities from Intact Tombs Discovered at Dahshur North, 158–170, in: M. BARTA, F. COPPENS, and J. KREJČÍ (eds.), *Abusir and Saqqara in the Year 2010/1*, Prague.
- BAGH, T.
 2013 *Levantine Painted Ware from Egypt and the Levant*, Tell el-Dab^a XXIII, Vienna.

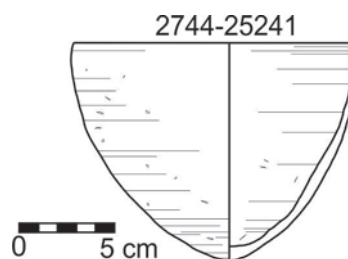

Fig. 21 Cup from unit (2744), building {2715} (drawing K. Danys and A. Wodzińska).

The material excavated during the 2017 season also revealed a very interesting cemetery of the early 18th Dynasty with tombs containing pottery characteristic of cemeteries located to the south, for instance, in the Memphite region and the Fayum Oasis. The pottery from the settlement of the early 18th Dynasty reflects mostly consumption. It is interesting that neither storage, nor preparation of food on a larger scale is visible, indicating that the area was at least partly provisioned.

Several houses of the Third Intermediate Period have been excavated. The pottery found in well-defined structures reflects all stages of the preparation and consumption of food, including storage, preparation, cooking, serving and discarding broken pots. There is no specific function of the houses – all of them display more or less the same pattern. An interesting vessel was found in an oven. It is a fish vase, which was probably produced during the late New Kingdom and used through the early Third Intermediate Period. Two plates might reflect some ritual aspects of life in the houses of the Third Intermediate Period.

⁶¹ JARMUZEK et al. 2019, Fig. 13.

- BIETAK, M.
1991 *Ein Friedhofsbezirk der Mittleren Bronzezeitkultur mit Totentemple und Siedlungsschichten*, Tell el-Dab^a V, Wien.
- BOURRIAU, J.
1987 Pottery Figure Vases of the New Kingdom, *Cahier de la Céramique Égyptienne* 1, 81–96.
2010 *Kom Rabia: The New Kingdom Pottery*. The Survey of Memphis IV, Egypt Exploration Society Excavations Memoirs 93, London.
- BREWER, D.J. and FRIEDMAN, R.
1989 *Fish and Fishing in Ancient Egypt*, Warminster.
- BRUNTON, G. and ENGELBACH, R.
1927 *Gurob*, British School of Archaeology in Egypt 41, London.
- CROWFOOT PAYNE, J.
1993 *Catalogue of the Predynastic Egyptian Collection in the Ashmolean Museum*, Oxford.
- DREYFUS, R.
2005 Animal Vases, 242–253, in: C.H. ROEHRING, D. DREYFUS, and C.A. KELLER (eds.), *Hatshepsut from Queen to Pharaoh*, New Haven-London.
- FAY, B.
1998 Egyptian Duck Flasks of Blue Anhydrite, *Metropolitan Museum Journal* 33, 23–48.
- FIRTH, C.M. and GUNN, B.
1926 *Teti Pyramid Cemeteries*. Excavations at Saqqara, Le Caire.
- FORSTNER-MÜLLER, I.
2008 *Die Gräber des Areals A/II von Tell el-Dab^a*, Tell el-Dab^a XVI, Wien.
- GEUS, F.
2004 Sai, 114–121, in: D.A. WELSBY and J.R. ANDERSON (eds.), *Sudan Ancient Treasures*, London.
- EL-HANGOURY, M.S.
2003 *Eighth Nome of Lower Egypt in the Second Intermediate Period*. *Archaeological Research* (unpublished PhD dissertation in Arabic), University of Tanta.
- HÖRBURGER, J.O.
2007 Black Lustrous Wheel-Made Ware in Egypt: The Distribution of a Cypriot Import, 107–113, In: I. HEIN (ed.), *The Lustrous Wares of Late Bronze Age Cyprus and the Eastern Mediterranean, Papers of a Conference, Vienna 5th–6th of November 2004*, Vienna.
- HUDEC, J., DUBCOVÁ, V., HULKOVÁ, L., and WODZIŃSKA, A.
2019 Formation of an Empire. Results of the Season 2017 in Tell el-Retaba, *Ä&L* 29.
- JARMUZEK, L., RZEPKA, S., and RYŠ, A.
2019 Tell el-Retaba 2017. Third Intermediate Period Settlement, *Ä&L* 29.
- RUSSMAN, E.R.
2001 *Eternal Egypt. Masterworks of Ancient Art from the British Museum*, London.
- RZEPKA, S., HUDEC, J., JARMUZEK, L., DUBCOVÁ, V., HULKOVÁ, L., WODZIŃSKA, A., ŠEFČÁKOVÁ, A., and STOPKOVÁ, E.
2017 From Hyksos Tombs to Late Period Tower Houses. Tell el-Retaba – Seasons 2015–2016, *Ä&L* 27, 19–85.
- RZEUSKA, T.
2001 Pottery from the Temple of Thutmose III at Deir el Bahari, *Études et Travaux* 19, 300–328.
2006 *Pottery of the Late Old Kingdom. Funerary Pottery and Burial Customs*, Saqqara II, Warsaw.
- SCHIESTL, R. and SEILER, A.
2012 *Handbook of Pottery of the Egyptian Middle Kingdom*, vol. 1, Vienna.
- VANDIER D'ABBADIE, J.
1972 *Catalogue des objets de toilette égyptiens*. Musée du Louvre, Paris.
- WODZIŃSKA, A.
2011 Pottery and Chronology. Preliminary Remarks on Ceramic Material from Tell el-Retaba, 1015–1036, in: D.A. ASTON, B. BADER, C. GALLORINI, P. NICHOLSON, and S. BUCKINGHAM (eds.), *Under the Potter's Tree. Studies on Ancient Egypt Presented to Janine Bourriau on the Occasion of her 70th Birthday*, OLA 204, Leuven-Paris-Walpole, Ma.
2015 Tell el-Retaba: Ceramic Survey 2007, 521–543, in: P. KOUSOULIS and N. LAZARIDIS (eds.), *Proceedings of the Tenth International Congress of Egyptologists, University of the Aegean, Rhodes, 22-29 May 2008*, OLA 241, Leuven-Paris-Bristol, CT.